

PW

MARCHWOOD

30A POWER SUPPLY UNIT part 1

by Nick Allen-Rowlandson BSc G4JET

One of the most useful pieces of equipment needed by anyone pursuing radio or electronics as a hobby is a good power supply. It needs to be reliable and able to give years of hard service without needing attention and if it is to be built at home it must be simple to construct and set-up.

The PW Marchwood was designed as an all-purpose supply capable of powering several transceivers and other 12V equipment. The output voltage is adjustable over a small range to allow for powering mobile transceivers which are rated to produce maximum power output at 13.8V. The maximum current available from the PW Marchwood is 30A on a continuous basis provided that the heat-sinking arrangements are adequate.

To achieve the required reliability the supply is protected against short circuits, thermal runaway, overvoltage and even operator impatience. A soft-start facility is incorporated to prevent the large charging currents associated with the reservoir capacitors causing problems.

The main problems to be overcome in presenting high current power supplies for home construction are the mains transformer and the case. In the design of the PW Marchwood both of these have been overcome and arrangements have been made with suitable suppliers. The design of the transformer is also detailed to allow constructors to arrange with a local transformer maker for one to be made.

Circuit Design

The PW Marchwood is designed around the ubiquitous LM723 regulator chip. This contains a buffered reference voltage and a low current (100mA) regulator stage. It is worth taking a look at how the fault circuitry is configured in the LM723 to understand the operation of the over-current and overtemperature protection circuitry of the power supply. Referring to Fig. 1.1, when the voltage



across the current sensing resistor R18 is large enough to turn on TrA, TrB is progressively turned off, preventing the output current from rising to a higher value. This results in the output voltage being reduced. If the load is such that the output voltage falls to less than about 7V, diode D3 starts to conduct and takes over the job of turning on TrA, shutting off the regulator completely. In this condition the regulator is latched in the off state.

One way to reset the regulator is to turn TrA off. When this is done it must be done in such a way that if the fault is still present at the output, the regulator is still able to protect itself. If the external load is removed R15 is able to raise the output voltage to a high enough value to make D4 conduct and reverse bias the emitter-base junction of TrA. It is only able to do this if the load is either removed completely or reduced to a few milliamps. If the load draws more current then the output voltage is held low enough to prevent TrA from being turned off. Zener diode D5 prevents the output voltage rising above 10V when no load is applied to the regulator since R15 could provide enough current to allow this to happen.

Thermal protection is provided by TS1 which, upon reaching 75°C, reduces its resistance from a high value to around 100Ω. This turns on Tr1 which turns the regulator off in the same manner as TrA and also gives an indication of a temperature fault via the l.e.d. D1 (Fig. 1.3). When Tr1 is turned on, the regulator turns off as before and latches off in the same way until the temperature reduces and the load is removed.

When designing the output stage it must be realised that for reliable operation the junction temperature of the transistors must be kept to reasonable levels even in the case of short circuits. The power dissipated in the output stage when regulating 30A will be about 180W (assuming 12V output and 18V unregulated input to the regulator). The final design of the output stage consists of five 2N3055 transistors connected in parallel each with its own 0.11Ω emitter resistor to ensure current sharing. One of these resistors is used to monitor load current. The pre-driver transistor Tr2 ensures that there is enough current gain as the LM723 is only capable of supplying 100mA. The complete circuit is shown in Figs. 1.2 and 1.3.

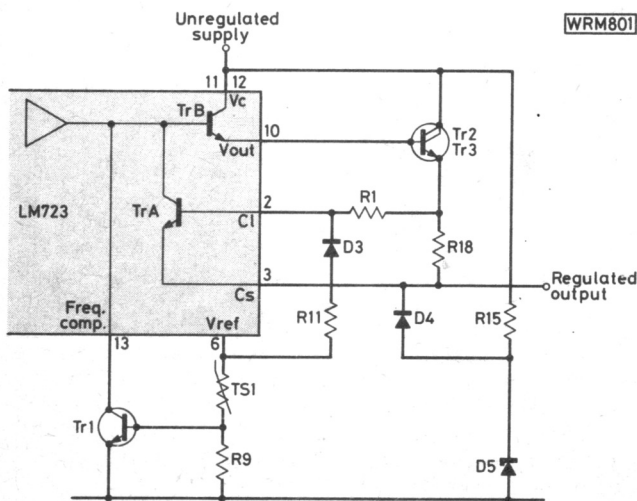
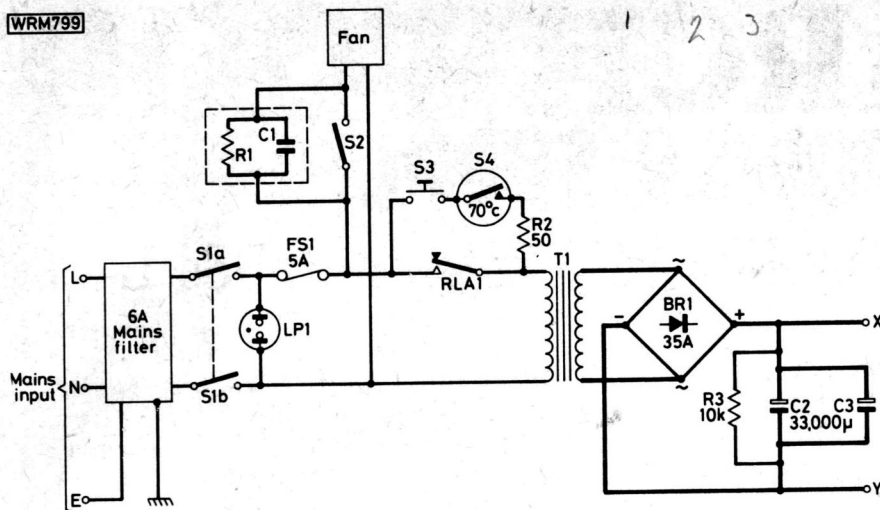

Fig. 1.1: Outline of the protection circuits

WRM799



◀ Fig. 1.2: Circuit diagram of the unregulated section showing the soft-start and fan supply. The indicator lamp LP1 is built into the mains switch S1

Fig. 1.3: Circuit diagram of the regulator and protection circuits. The high-current feeds are indicated by heavier lines. Resistors R31 and R32 are included to prevent the remote sense lines becoming unrelated to the main output terminals if the links are inadvertently left out ▼

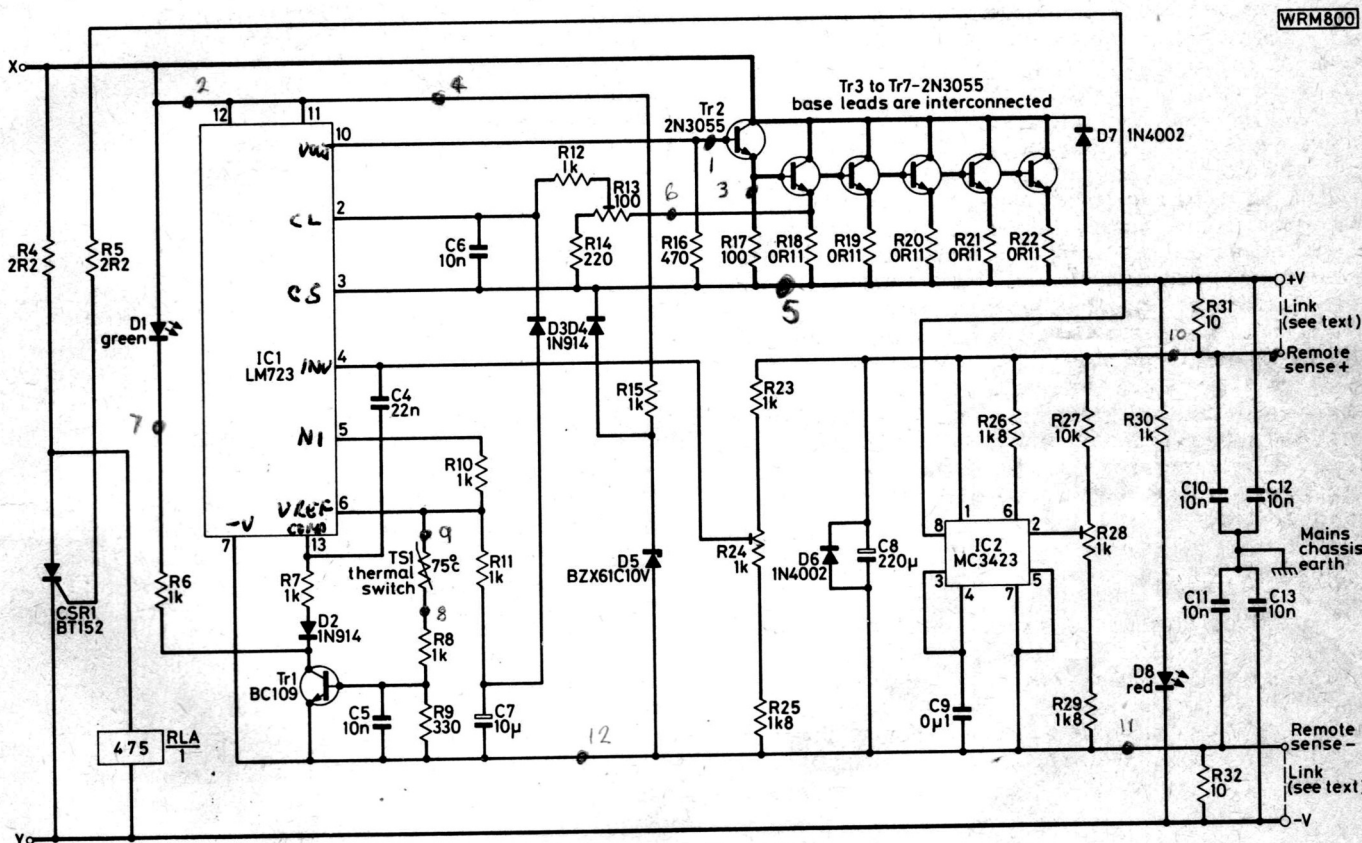

WRM800

Protection Circuits

The most difficult aspect of designing a heavy current p.s.u. such as the *PW* Marchwood is the provision of reliable protection circuitry. The current limit and over-temperature circuits have already been explained. This leaves the overvoltage and main fusing circuits.

It is important to be able to shut down the supply in the event of the voltage at the output terminals rising above the safe level for the load. In the case of a transceiver this is usually about 15V. The usual cause of overvoltage is total failure of the pass transistors. Failure resulting in these going open circuit is harmless but failure with them going short-circuit puts the full unregulated output from the capacitor bank across the load terminals. Various means of ensuring that the output voltage cannot rise above, say, 15V have been suggested but most do not even work satisfactorily for low-current supplies let alone a 30A p.s.u. such as the *PW* Marchwood.

Practical Wireless, June 1983

Any system which relies on taking out a fuse in the low-voltage circuits will not work reliably and safely.

A study of fuses in general will show that a fuse which will carry 30A continuously requires a current of around 500A to rupture in 4ms, 200A in 500ms and 100A to go in 10s. The energy available to rupture the fuse is stored in the capacitor bank and, assuming a short-circuit condition, is all that is available since it cannot be replaced during the next mains half-cycle. Even with the 66 000µF capacitor bank used in this design it is very doubtful that enough energy can be obtained in the 10ms available to rupture a fuse in the low-voltage circuits. Added to this problem is the very high cost of reliable and safe fuses and holders capable of carrying 30A and containing the explosive forces released when the fuse blows.

The system used in the *PW* Marchwood is a form of circuit-breaker which removes the mains supply when a

PW MARCHWOOD

fault occurs. The overvoltage circuitry uses a 3423 over-voltage protector chip which continuously monitors the output voltage. To prevent tripping by noise spikes the circuit has a delay built in. Capacitor C9 charges up when the output voltage rises above the reference level set by R28 and if the overvoltage remains long enough to allow C9 to charge up to the same value as the reference level the output is activated, firing the thyristor CSR1.

The thyristor effectively shorts out the relay RLA which switches the mains supply off. At the same time the thyristor discharges the capacitor bank through the 2.2Ω resistor R4. This prevents the capacitor bank from being discharged too rapidly with possibly messy results, and also limits the thyristor current.

With no voltage on the capacitor bank the relay RLA is de-energised and hence the mains supply is switched off. This prevents the supply being turned on simply by operating the mains switch S1. To start the supply it is necessary to bypass the contacts of RLA and this is performed by the PUSH TO START switch S3. The low value resistor R2 in series with S3 limits the mains current to a level which allows the mains fuse FS1 to be of the quick-blow type rather than having to withstand a high surge current. To protect the p.s.u. from impatient operators who might try to start the supply either on load or with a fault condition existing, a thermal switch is used which operates when R2 gets too hot. This switch opens at 70°C and does not close again until it cools to 55°C.

This approach to protection, whilst appearing complicated, is in fact the most cost-effective way.

**CONSTRUCTION
RATING** **Advanced**

BUYING GUIDE

The construction of this project is not inherently difficult but requires care and attention to detail if the resulting power supply is to be successful.

Components are readily available from several advertisers while the mains transformer will be made available to order as will the specially designed case. Details will be given in Part 2.

**APPROXIMATE
COST** **£95**

Part 2

In the second part we will deal with the construction and setting-up of the *PW* Marchwood power supply including details of where to obtain the case and other critical components.



MARCHWOOD

30A POWER SUPPLY UNIT part 2

by Nick Allen-Rowlandson BSc G4JET

In the first part we looked at the theory behind the design of a high-current power supply and its protection circuits. In this part the construction of the unit will be outlined. As this project is intended for the more advanced constructor detailed instructions will not be given, indeed since a specially designed cabinet is available ready punched to accept all the specified components such instructions are not really needed.

The control and overvoltage circuits are built on a simple printed circuit board which is bolted on spacers above the mains transformer. The wiring to this p.c.b. can be relatively small in size since only quite small currents are handled.

Casework

The case has been specially designed for this project by Newrad and is available from them ready drilled and formed but in "knocked down" form. Assembly is straightforward and should present no problems. The mains transformer is bolted to the base and front panel to increase the overall rigidity. With the mains transformer in place the unit is heavy and care must be taken when moving it around the bench not to trap your fingers under the sides.

The two smoothing capacitors are mounted in clips bolted to the floor along with the bridge rectifier, which should be fitted with heatsink compound to help get rid of the heat to the case. The relay is also mounted in a plug-in base screwed to the floor.

Heatsink

The output transistors need to be properly mounted onto an efficient heatsink to ensure reliable continuous operation at anything approaching maximum current. The prototype used the TO3 metal cased 2N3055 transistors and these are shown in the photographs and drawings. The plastic cased TIP3055s can also be used and are mounted on the same side of the heatsink as the current sharing resistors. Mica washers are used for both types.

The drawing, Fig. 2.1, shows the method of assembling the heatsink and output transistors together with the resistors and thermal switch. Heatsink compound must be used to ensure good thermal contact between the heatsink and transistor bodies through the insulating washers.

The heatsink extrusion used is available in different lengths and may need cutting to the required lengths to fit

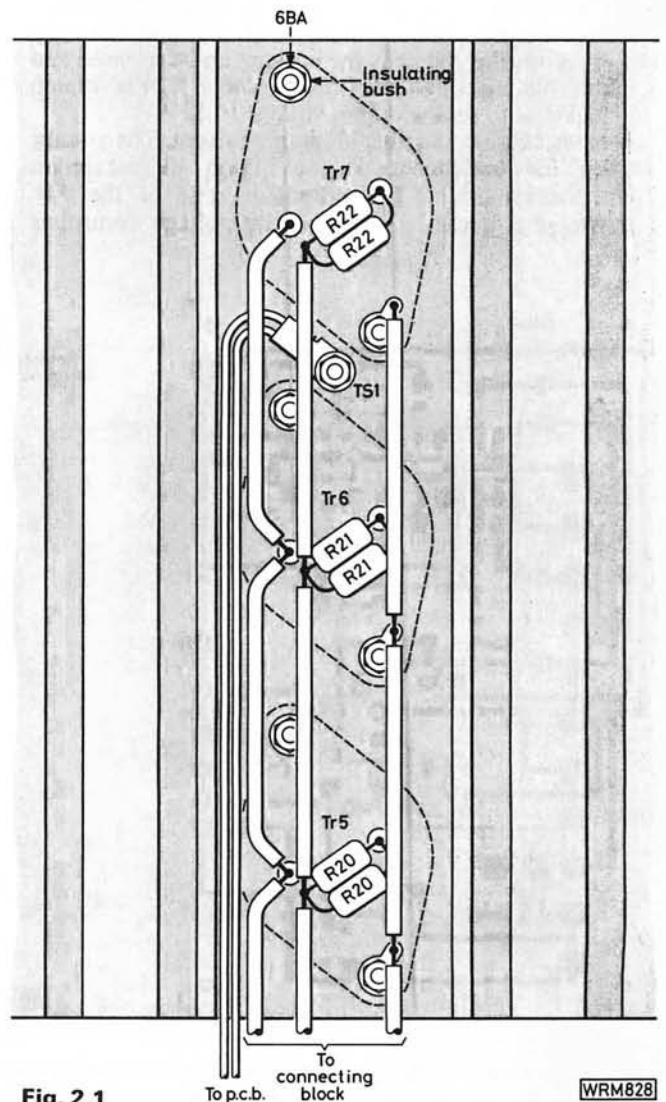
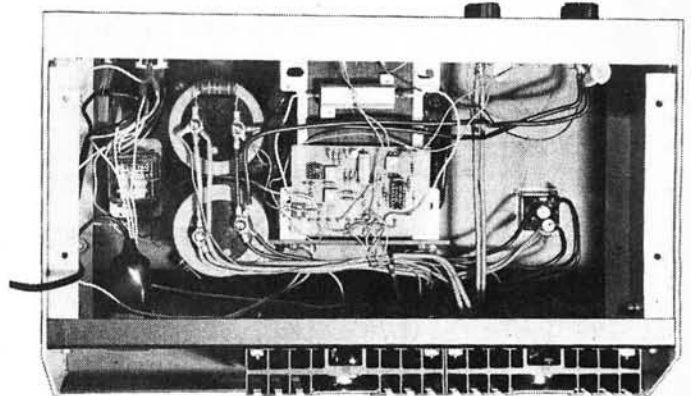
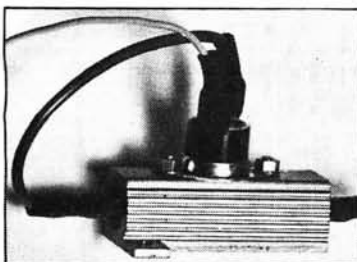

Fig. 2.1

WRM828



The method of mounting the thermal protection switch onto the soft start resistor

the case. The heatsink extrusions must not cover the slot in the back of the case but are mounted just above the slot. Air is then forced out of the case by the fan and up over the heatsink fins.

The fan is mains driven and is mounted in the roof of the cabinet together with an air filter. Air is drawn down into the cabinet by the fan and, as the only exit is via the horizontal slot under the heatsinks, the air is forced up over the fins to cool the output transistors.

Power Cabling

The main high-current wiring inside the unit **must** be carried out in a suitable gauge of wire. At least 4mm² pvc insulated cable should be used and this can be obtained most easily from 4mm² twin and earth mains cable. Suitable tags should be used to connect this cable to the capacitor terminals and it is also best to bind joints with thin tinned copper wire before soldering them.

Testing

Before switching on check and double check all your wiring and assembly work. With the current capability of the supply any fault is likely to be catastrophic, not to mention spectacular!

Set R13, R24 and R28 fully clockwise, ensure that the REMOTE SENSE terminals are linked to the OUTPUT terminals, fit a 3A fuse into the mains fuse holder and switch on. No output voltage should appear at the terminals until the PUSH TO START button is pressed when the voltage across the capacitor bank should slowly rise until the relay pulls in. When this happens the button can be released and the output voltage checked. Preset resistor R24 is rotated anti-clockwise to set the output voltage to 13.4V.

Here we come up against a minor problem. The voltage specified for equipment depends upon its maximum current consumption. The output voltage of the PW Marchwood is preset, so, unless the voltage control is

Load current (A)	Stabilised voltage (V)
Less than 6	13.8
6 to 16	13.6
16 to 36	13.4
36 to 50	13.2
Greater than 50	13.0

BS6160: Pt 1: 1981 and IEC 489-1-1976
Measurement for Radio Equipment used in the mobile services, Pt. 1.

taken to a potentiometer mounted so as to be accessible from the front panel a decision has to be taken as to whether to set the voltage low or high or somewhere in between. The specified voltage for different current consumptions is given in the table.

Overvoltage Trip

To set the overvoltage trip the output voltage needs to be temporarily increased to the level at which the trip is required to operate, usually about 15V. So increase the output voltage using R24. Now slowly adjust R28 until the overvoltage trip fires and the relay drops out. Reduce the output voltage, restart the supply and slowly increase the output voltage until the trip again fires. Check the output voltage when this happens and readjust R28 if it is not 15V. Reset the output to 13.4V using R24.

Current Limit

The supply can now be tested on load. To do this properly you will need some form of resistive load which can be varied easily and is capable of loading the output to 30A at 13.4V. In other words a total resistance of 0.44Ω at 400W! The prototype was tested with a combination of resistive mats and an Avo Model 8 with a specially made and calibrated high current shunt. The shunt consisted of a length of 16s.w.g. copper wire the length of which was adjusted to reduce the meter deflection, with 10A flowing on

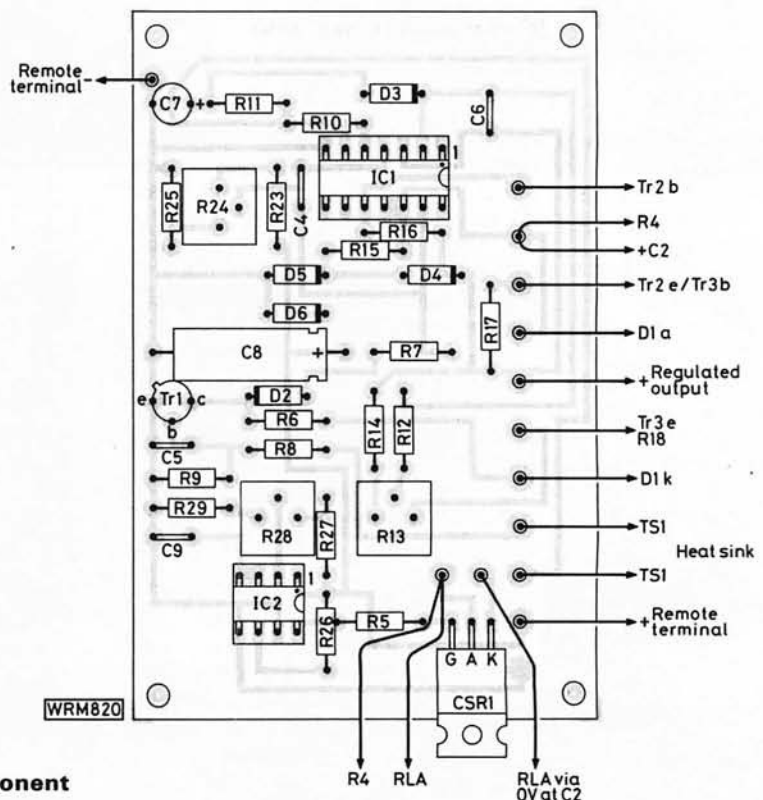
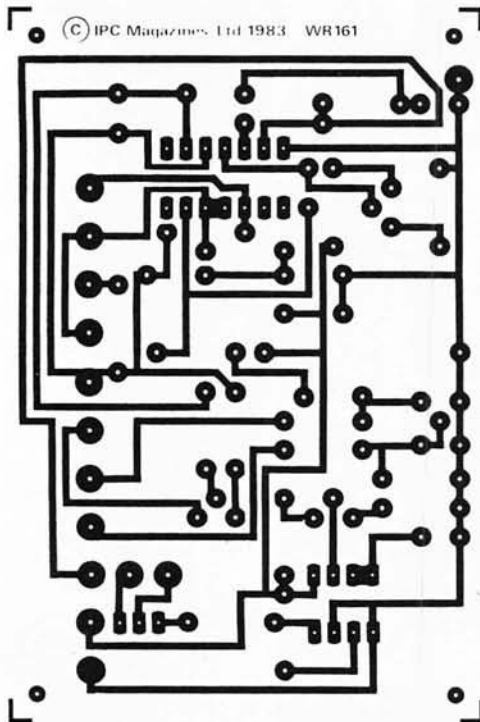

Fig. 2.1: Copper track pattern and component placement shown full size

★ components

Resistors

Carbon Film $\frac{1}{4}$ W 5%

2.2 Ω	1	R5
100 Ω	1	R17
220 Ω	1	R14
330 Ω	1	R9
470 Ω	1	R16
1k Ω	9	R6, 7, 8, 10, 11, 12, 15, 23, 30
1.8k Ω	3	R25, 26, 29
10k Ω	2	R3, 27

2.5W Wirewound

0.22 Ω	10	R18, 19, 20, 21, 22 (Paralleled pairs)
10 Ω	2	R31, 32

25W Aluminium-clad wirewound

2.2 Ω	1	R4
--------------	---	----

50W Aluminium-clad wirewound

47 Ω	1	R2
-------------	---	----

Top-adjusting cermet preset

100 Ω	1	R13
1k Ω	2	R24, 28

Capacitors

Resin dipped ceramic

10nF	6	C5, 6, 10, 11, 12, 13
22nF	1	C4
0.1 μ F	1	C9

Tantalum bead

10 μ F 35V	1	C7
----------------	---	----

Electrolytic axial lead

220 μ F 25V	1	C8
-----------------	---	----

Electrolytic, computer grade, high-ripple (23A)

33000 μ F 40V	2	C2, 3 (RS 103-137)
-------------------	---	--------------------

Semiconductors

Diodes

1N914	3	D2, 3, 4
1N4002	2	D6, 7
Red l.e.d.	1	D1
Green l.e.d.	1	D8
BZX61C10V	1	D5
Bridge 35A 200V	1	BR1

Thyristors

BT152	1	CSR1
-------	---	------

Transistors

BC109	1	Tr1
2N3055	6	Tr2, 3, 4, 5, 6, 7 (see text)

Integrated circuits

LM723	1	IC1
MC3423	1	IC2 (RS 307-890)

Miscellaneous

Transformer 16V r.m.s. 43A r.m.s. (see text); Heat-sinks 1.1°C/W 152 x 130 x 32mm (2); T03 mounting kits (6); Heatsink compound; IEC 6A mains filter plug; Illuminated mains rocker switch d.p.d.t.; Mains push button switch s.p.s.t. 3A alternative action; Mains push button switch s.p.s.t. 3A momentary action; Fuse holder 20mm panel mounting; 6A 20mm quick-blow fuse; Insulated terminals 4mm black (1), red (1); Insulated terminals 30A black (1), red (1); Fan 120mm dia 240V a.c. (RS 509-226) with filter pads to match; Contact suppressor 250V a.c. (R1/C1) RS 238-463; Relay Octal plug-in, 24V d.c. 475 Ω (RS 348-784); Compact screw base for relay (RS 402-355); Printed circuit board; Case (see text); 4mm² copper wire pvc covered (see text).

The case is available direct from Newrad Instrument Cases Ltd., Tiptoe Road, Wootton, New Milton, BH25 5SG. Tel: New Milton 615774. Price £21.00 inclusive. The mains transformer can be obtained from Hilton Transformers, North Causeway, Wareham, Dorset. Tel: Wareham 51646. Price £21.50 inclusive. A kit of semiconductors together with a p.c.b. is available from the author at 19 Kings Avenue, Christchurch, Dorset. Price £20.00 inclusive.

the 10A range, to about one-third of full scale (3A). Remember to multiply the meter readings by the scaling factor of your shunt and do not allow high currents to pass for longer than is necessary to take test measurements.

With the supply loaded to just 30A adjust R13 until the output current drops back to 30A. This sets the current limit level.

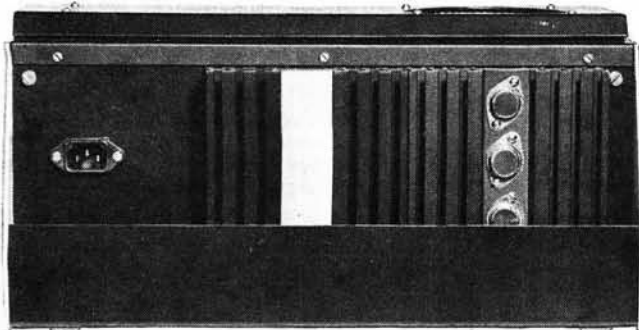

Rear view of the case showing the filtered mains plug and heat sinks. The cover over the right-hand transistors has been removed

Practical Wireless, July 1983

When running the *PW* Marchwood at currents over about 5A the fan should be used and to prevent the surge from the fan tripping the protection circuits the fan should be switched on before starting up the supply.

Electro-magnetic Compatibility

The *PW* Marchwood has been thoroughly tested including e.m.c. investigation and for this we would like to thank G8MCQ who is professionally involved with this type of testing. The results of these tests were as follows:

1V r.f. 0.5 to 500MHz injected into mains input	No effects
5V r.f. 0.5 to 150MHz injected into d.c. output	No effects
1kV pulses, 1 μ s rise, 10 μ s fall, injected into mains input	No problems

Since its construction the prototype has been used extensively with full legal power capability h.f. transceivers with no evidence of any regulation or tripping problems. The supply has also been used to power v.h.f. and u.h.f. equipment again with complete freedom from problems. ●